

Heartstart® 911

Directions for Use

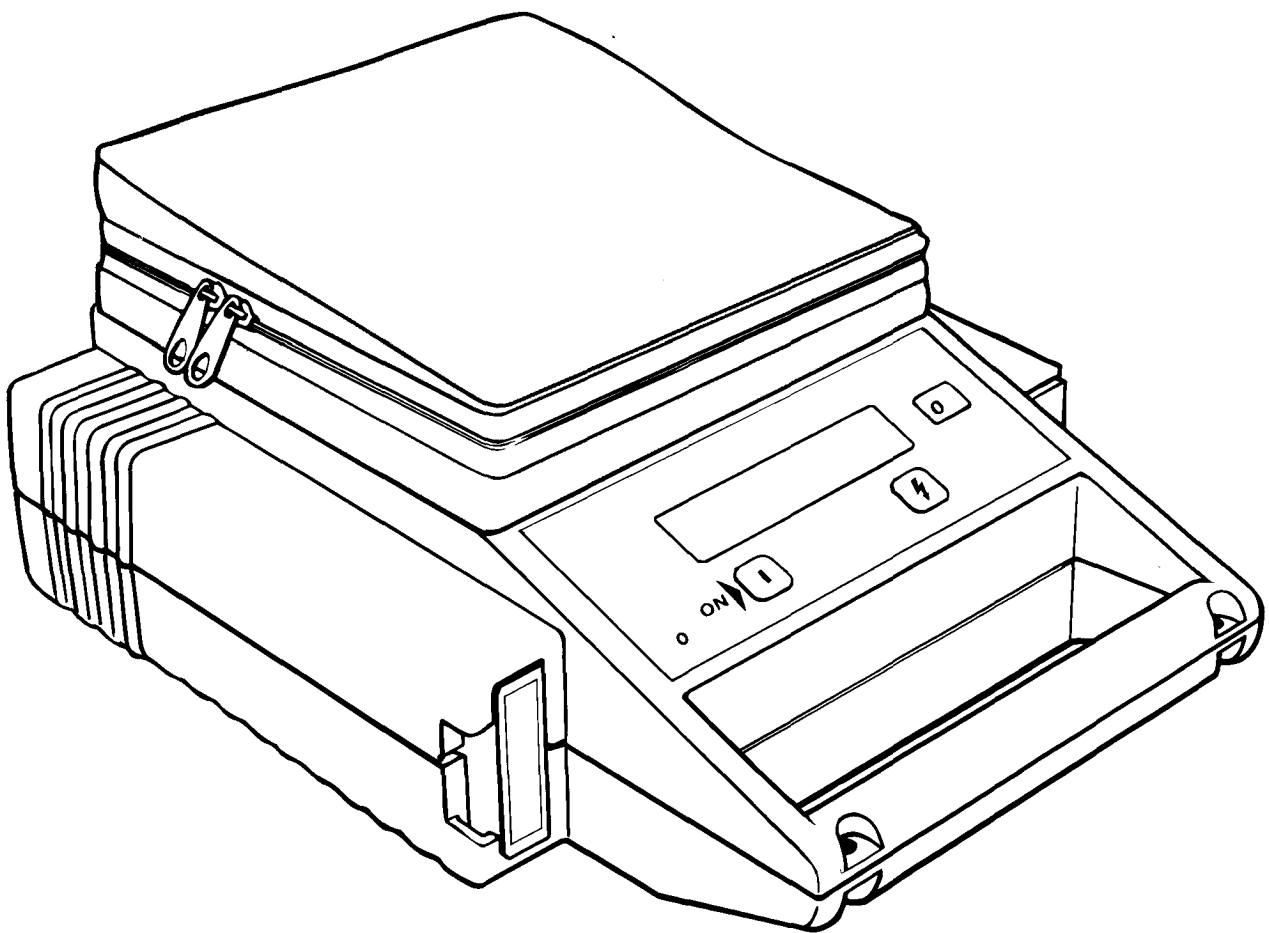

BJ
38



Laerdal
helping save lives

1. CAUTIONS AND WARNINGS

- The Heartstart 911 is to be used only by trained, authorized personnel. Operators should be familiar with the information contained in these Directions for Use prior to using the device.
- Do not apply the Heartstart 911 to a person who is conscious, has a pulse, or is breathing.
- Do not use the device in the presence of flammable anesthetic agents or in environments in which an electrical spark could ignite an explosion.
- Do not attempt to discharge the device except as indicated in the instructions. A defibrillator contains dangerous electrical currents that can cause death or injury if the device is used or discharged improperly. Do not discharge with the electrodes electrically shorted together or left unattached and open.
- Do not disassemble the device. There are no user serviceable components in the device and dangerous high voltages and electrical currents are present. Therefore, do not attempt to repair. Refer any problem to Laerdal for service.
- Do not come in contact with the patient during defibrillation. Ensure that others are not in contact with the patient during defibrillation. A shock hazard is present from any contact with the patient or equipment on which the patient may be supported, connected, or in contact with during defibrillation.
- Use only approved, self-adhesive, single use, defibrillation electrodes within their expiration date. Discard electrodes after use following local disposal protocols. Do not reuse electrodes or use electrodes from packages that have been opened for an extended period prior to use. Use only the defibrillation electrodes supplied with the device or re-supplied from Laerdal or its authorized distributors. Do not use monitor electrodes with the Heartstart 911.
- Use only batteries supplied by Laerdal or its authorized distributors for operation of the device. Two fully charged and maintained batteries should be kept with the Heartstart 911 when in use.
- Use only MCM Plus semiautomatic Medical Control Modules, which are supplied with the device or re-supplied from Laerdal or its authorized distributors.
- Disconnect the patient from any equipment that is not defibrillation protected or that may interfere with the operation of the Heartstart 911. The Heartstart 911 input is protected from external defibrillation pulses and will not absorb excess energy.
- Do not use the defibrillator on patients with cardiac pacemakers. Signals from cardiac pacemakers may disturb the ECG signals.
- Do not use the defibrillator on children with body weights below 36 kg.
- Do not operate the defibrillator in a moving vehicle. If the use of the Heartstart 911 is indicated during transportation, bring the vehicle to a halt before operating the defibrillator. **DO NOT START ECG ANALYSIS UNTIL THE VEHICLE IS BROUGHT TO A HALT AND THE PATIENT AREA IS CLEARED.**
- The use of radio transmitters directly next to the Heartstart 911 is not recommended as the device may exhibit sensitivity to the radio frequency signals. Similarly, the Heartstart 911 produces radio frequency noise to which communication equipment may exhibit sensitivity. Interference, if noted at all, may be corrected by repositioning equipment or cables to increase the distance between them.
- Follow all recommended care and maintenance procedures contained in this manual.

2. CONTENTS

| | |
|--|----|
| 1. Cautions and warnings | 2 |
| 2. Contents | 3 |
| 3. Introduction | 4 |
| 3.1 Unpacking | 4 |
| 3.2 Before using | 4 |
| 3.3 Warranty | 4 |
| 3.4 Indications and contraindications | 4 |
| 3.5 Available accessories | 5 |
| 3.6 Heartstart 911 ECG analysis and operation | 5 |
| 4. Device overview | 6 |
| 4.1 Device features | 6 |
| 5. Operation | 8 |
| 5.1 Device protocols | 8 |
| 5.2 Pre-use checks | 8 |
| 5.3 Connecting the Heartstart 911 to a patient | 8 |
| 5.4 Operation of the Heartstart 911 | 9 |
| 5.5 Device warnings during operation | 14 |
| 5.6 Medical control | 16 |
| 6. Setup functions | 18 |
| 6.1 MCM-clear | 18 |
| 6.2 Download | 18 |
| 6.3 Clock | 19 |
| 6.4 Volume | 19 |
| 6.5 Versions | 20 |
| 6.6 Auto-test | 20 |
| 6.7 Selftest | 21 |
| 7. Maintenance | 22 |
| 7.1 Battery installation, charging and care | 22 |
| 7.2 After-use and periodic checks | 23 |
| 7.3 Automatic selftest check | 23 |
| 7.4 Device cleaning | 23 |
| 7.5 Device maintenance | 23 |
| 8. Specifications | 24 |
| 9. Trouble shooting list | 30 |
| 10. Appendix A Heartstart 911 preparedness check list ... | 32 |
| 11. Appendix B Heartstart 911 periodic check list | 33 |

INTRODUCTION

The Heartstart 911 is a lightweight, portable, battery-powered, semi-automatic defibrillator. When connected to a patient via cables and self-adhesive defibrillation electrodes and turned on, the Heartstart 911 prompts the operator to take specific actions, analyses the ECG, charges the shock capacitors and indicates whether a shockable rhythm is present. The operator discharges the device.

The Heartstart 911 is intended for use by emergency care personnel who have completed training and certification requirements applicable to the use of a defibrillator. It is specifically designed for use in early defibrillation programme with medically approved patient-care protocols.

The recognition of a shockable arrhythmia, ventricular fibrillation, (or rapid ventricular tachycardia), is based on the Heartstart 911's ECG analysis system.

ECG signals are acquired via two disposable, defibrillation electrodes. Contact between the electrodes and the patient is monitored to ensure proper electrode contact. Discharge energy levels of 200, and 360 joules are available.

Power is provided from an easily exchanged, rechargeable, sealed lead-acid battery installed in the side of the Heartstart 911.

For further battery maintenance details see page 22.

If the Heartstart 911 is being charged with a Heartstart battery charger, an automatic device selftest can be performed at regular intervals.

Device status, warnings, and operating messages are presented on a two-line display. Three pushbuttons are used to operate the device. Voice messages or "prompts" reinforce important displayed messages.

Internal memory in the Heartstart 911 records information about device operation and stores up to 150 seconds of a patient's ECG that can be downloaded to a Medical Control Module Plus. The Medical Control Module Plus can store up to 20 minutes of a patient's ECG in its memory for later printing of a report. Printing is performed by separate equipment.

The Heartstart 911 is classified as a defibrillator with type BF risk current protection.

The trapezoidal type defibrillation waveform is in accordance with AAMI DF2-1989 standard.

The Heartstart 911 complies with AAMI DF39, AAMI DF2 and IEC 601 (EN 60601) standards, where applicable.

CE- Product is in compliance with essential requirements of council directive 93/42/EEC; Medical Device Directive.

3.1 Unpacking

After removing the Heartstart 911 from its shipping container, inspect for signs of damage. If there are signs of damage, immediately notify your Laerdal representative.

3.2 Before using

Check that all appropriate accessories are included with the Heartstart 911. Thoroughly review the operating instructions in this manual before operating the device. Ensure that all operators are familiar with these instructions. Additional copies of these Directions for Use are available upon request.

Locate the Heartstart battery and the battery charger supplied with the device. Review the procedures on battery installation, removal, and charging in Section 7. Charge batteries for a minimum of 16 hours to ensure a full charge before they are put into use.

Verify the correct device configuration has been received. If there are any problems with the device or accessories, contact Laerdal.

3.3 Warranty

See the warranty card for a description of the Heartstart 911 warranty. The warranty card also includes information on contacting Laerdal service in the event your Heartstart 911 requires service.

Complete and return the warranty card to Laerdal. Laerdal maintains a continuing product development and improvement programme and reserves the right to change materials, specifications, operation, and prices at anytime without notice.

All specifications are given at 20°C (68°F) unless noted otherwise.

3.4 Indications and contraindications

Indications

The Heartstart 911 is indicated for use on victims of cardiac arrest where there is apparent lack of circulation, as indicated by:

- Unconsciousness
- Absence of breathing
- Absence of pulse

Contraindications

Use of the Heartstart 911 is contraindicated on patients with any of the following conditions:

- Consciousness
- Presence of breathing
- Presence of pulse

The Heartstart 911 is not intended for use on patients with cardiac pacemakers where the ECG analysis system may not reliably indicate the requirement for a defibrillation shock. The Heartstart 911 is not intended for paediatric use or on patients whose weight is below 36 kg. The Heartstart 911 is not intended for use as a monitoring device.

The Heartstart 911 is not to be used in a moving vehicle or while the patient is being moved.

3.5 Available accessories

| Catalog # | Description |
|-----------|--|
| 93 03 10 | Soft case for Heartstart 911 |
| 90 38 00 | Heartstart ECG Simulator/Tester |
| 90 11 00 | Replacement battery |
| 90 28 00 | Battery charger, 100 V AC |
| 90 28 10 | Battery charger 120 V AC |
| 90 28 20 | Battery charger 230 V AC |
| N/A | Battery charger 12-28 V DC |
| 90 19 40 | Heartstart 911 charging rack |
| 90 27 00 | Battery charger adapter, for external battery charging |
| 92 01 00 | MCM Plus, semi-automatic |
| 92 06 20 | Heartstart 911 patient cable |
| 90 24 00 | Defibrillation electrodes, 10 pairs |
| 90 50 00 | Battery Tester |
| 91 00 20 | Heartstart Reporter |
| 92 03 00 | Heartstart Quick Reporter, Charger |
| 93 03 00 | Carry strap |

3.6 Heartstart 911 ECG analysis and operation



The ECG is analysed in 3 second segments. Device operation is determined by the outcome of two out of three ECG segments from the start of ECG analysis, as shown in the following table. The device will start charging after the first analysis indicating the presence of a shockable rhythm but at least one more such analysis is required before delivery of the SHOCK is allowed.

| 1st Analysis | 2nd Analysis | 3rd Analysis | OUTCOME |
|--------------|--------------|--------------|----------|
| TREAT | TREAT | Not Required | SHOCK |
| TREAT | NO TREAT | TREAT | SHOCK |
| NO TREAT | TREAT | TREAT | SHOCK |
| NO TREAT | NO TREAT | Not Required | NO SHOCK |
| NO TREAT | TREAT | NO TREAT | NO SHOCK |
| TREAT | NO TREAT | NO TREAT | NO SHOCK |

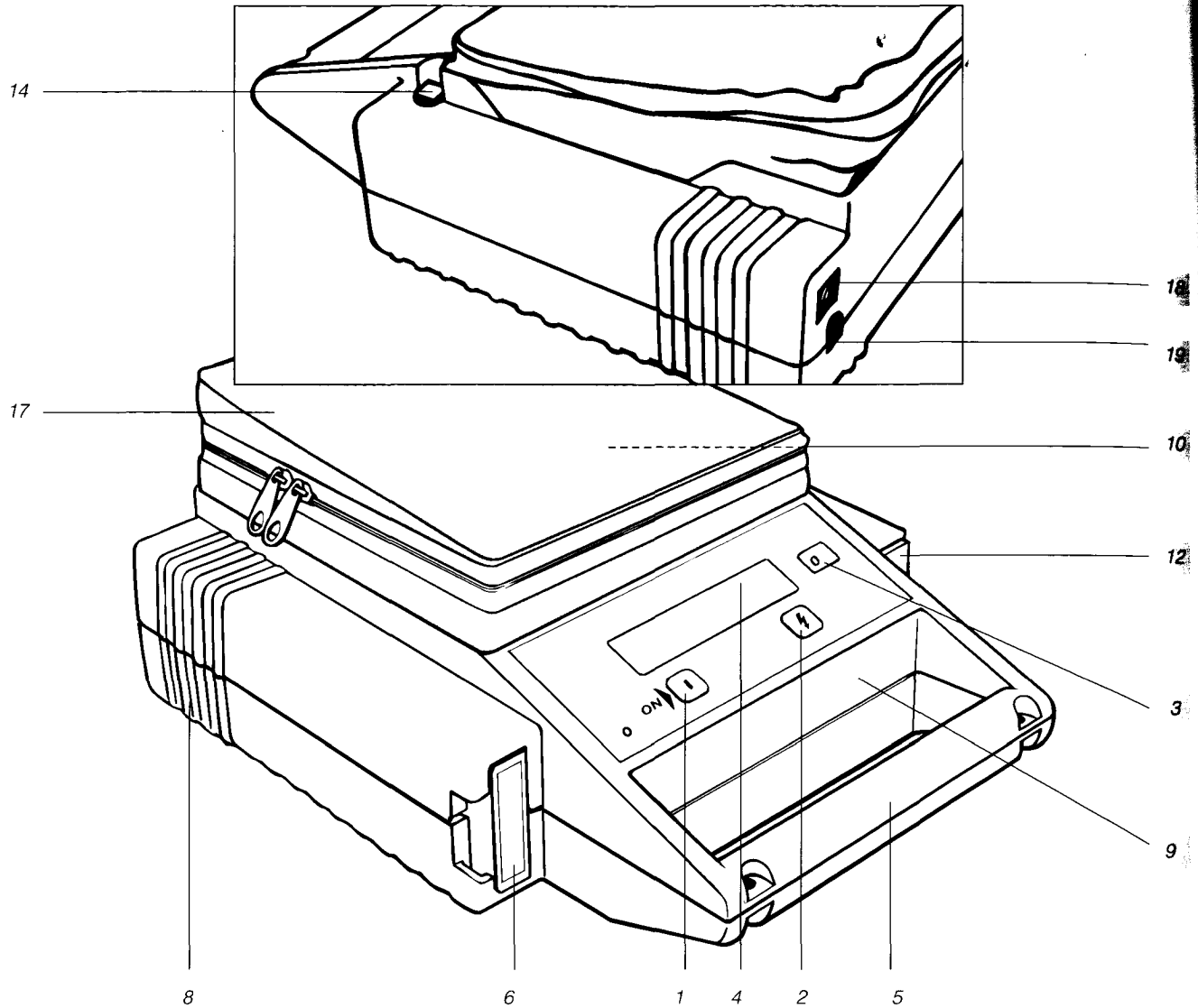
4. DEVICE OVERVIEW



4.1 Device features

- 1 **BUTTON: ON** 
This button operates in one of the following two modes.
 - Initially turns the Heartstart 911 ON. Press the button until a beep is heard.
 - When the display shows "ANALYSE", press this button to start ECG analysis, if indicated.
- 2 **Button:** 
When the display shows "SHOCK", pressing this button delivers the shock.
- 3 **Button:** 
Turns the device OFF and disarms any charge by internally discharging the capacitors.

- 4 **Display**
Provides operator prompts and device status.
- 5 **Carrying handle**
A carrying strap (optional) can be attached to the carrying handle.
- 6 **Medical Control Module receptacle**
- 7 **Optional Medical Control Module**
(MCM Plus semi-automatic)
A small solid state memory device that stores information about the defibrillator and ECG for remote printout.

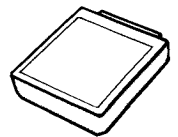

8 **Speaker**
Provides operator prompts and device status.
Volume is adjustable.

9 **Instruction label**
This label contains brief instructions for use of the Heartstart 911.

10 **Patient cable receptacle** inside storage pouch.

11 **Heartstart 911 patient cable**

Shielded two-lead patient cables are provided to connect to self-adhesive, single use, defibrillation electrodes. The patient cable can be detached from the defibrillator.

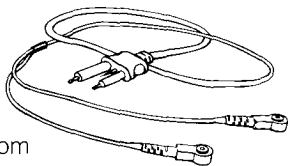

12 **Battery receptacle**

Insert battery with the contacts facing towards the device and the beveled edge facing down until the battery locks into place.

13 **Battery**

The rechargeable sealed lead-acid battery provides power for the Heartstart 911.

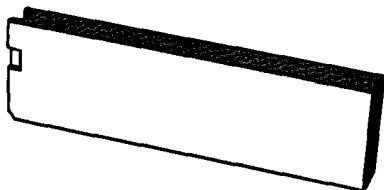

14 **Battery eject button**

A latch holds the battery in place when installed in the defibrillator. The battery is ejected by pressing down the eject button.

15 **Battery charger**

Battery charger supporting automatic self test of the Heartstart 911.

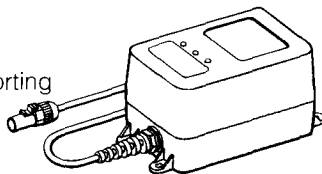

16 **Battery charger adapter**

Used for charging battery outside of device.

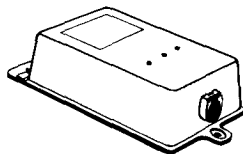

17 **Storage pouch**

Room for storing patient cable, spare battery, two sets of defibrillation electrodes and other accessories. The storage pouch is attached to the defibrillator.

18 **Receptacle for rack guidance and charging connector**

19 **Receptacle for charging connector**

Charging connector for in device battery charger if the Heartstart 911 is not installed in the charging rack.

20 **Defibrillation electrodes**

Self-adhesive, single patient use, defibrillation electrodes to be attached to patient's chest.

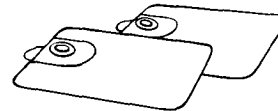

21 **Charging rack (optional)**

The Heartstart 911 is positioned on the rack by two pyramids, and is held in place by a fastener on the carrying handle.

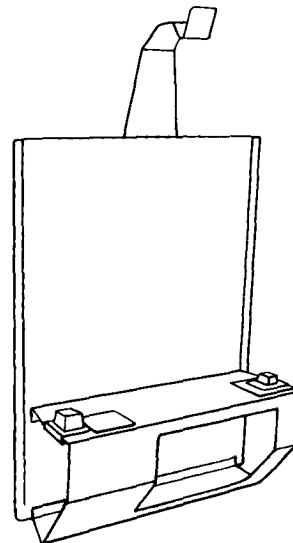

5. OPERATION

5.1 Device protocols

The Heartstart 911 operation is based on treatment protocols recommended by the American Heart Association and the European Resuscitation Council.

5.2 Pre-use checks

Verify the Heartstart 911 is in good working condition and equipped with at least the following before use (see After-use and periodic checks, section 7.2):

- Two sets of electrodes in sealed packages within expiration date.
- A fully charged and properly maintained battery (See Maintenance, section 7.1), installed in the Heartstart 911. If your system requires a second battery, ensure it is properly charged.

5.3 Connecting the Heartstart 911 to a patient

5.3.1 Verify cardiac arrest

Following medical protocols, verify:

unconsciousness

no breathing

no pulse

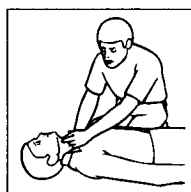
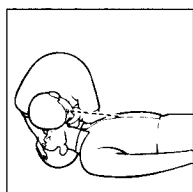
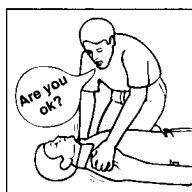

5.3.2 Prepare patient

- Expose the patient's chest by removing clothing. For patients with hairy chests, remove excess hair in the electrode placement areas.
- Remove all foreign materials, such as medicinal patches or lotions, from the skin prior to applying electrodes.
- Dry the patient's chest.

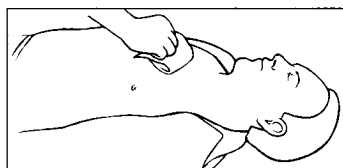

Note: It is important that the chest be clean and dry to ensure good electrode adhesion and contact. "CHECK ELECTRODES," or "ATTACH ELECTRODES" messages may occur if the patient's skin is not prepared correctly.

5.3.3 Attach electrodes to patient

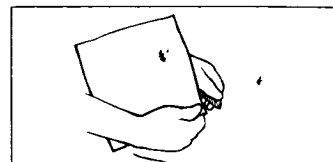

- Remove the electrodes from their sealed package.

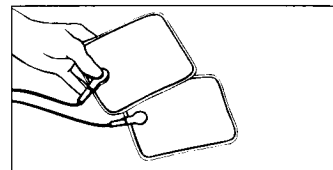

- Attach each electrode to the cable. Support the electrode on a firm surface and press each cable connector onto the electrode connector until it snaps in place, being careful not to overflex the electrodes.

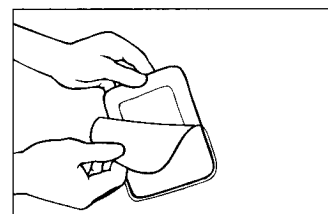

- Starting from the electrode connection end, peel off the protective backing from one electrode at a time.

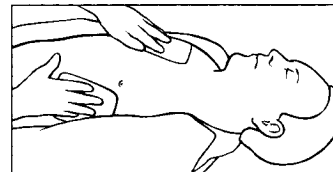

- Apply the electrode with the white connector to the patient's right chest next to the upper half of the sternum, below the clavicle. The red electrode is applied over the apex beat area of the chest, just below the left nipple ("white to right, red to ribs"). This ensures a modified lead II position with upright QRS complexes.
- Ensure electrodes are firmly attached by gently pressing on the electrode surface, especially at the edges.

Note: ECG monitoring electrodes are not intended for use with this device and will not connect to the Heartstart 911 patient cable.

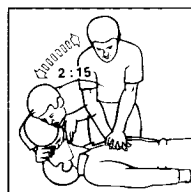

5.3.4 Administer CPR In accordance with protocols

5.4 Operation of the Heartstart 911

After power on, it is required that the operator presses the Analyse button to initiate the ECG analysis for each shock. Before turning the Heartstart 911 on, ensure that

the patient is motion free and absolutely still. No one should now be touching the patient. If operating in a moving vehicle, bring the vehicle to a halt.

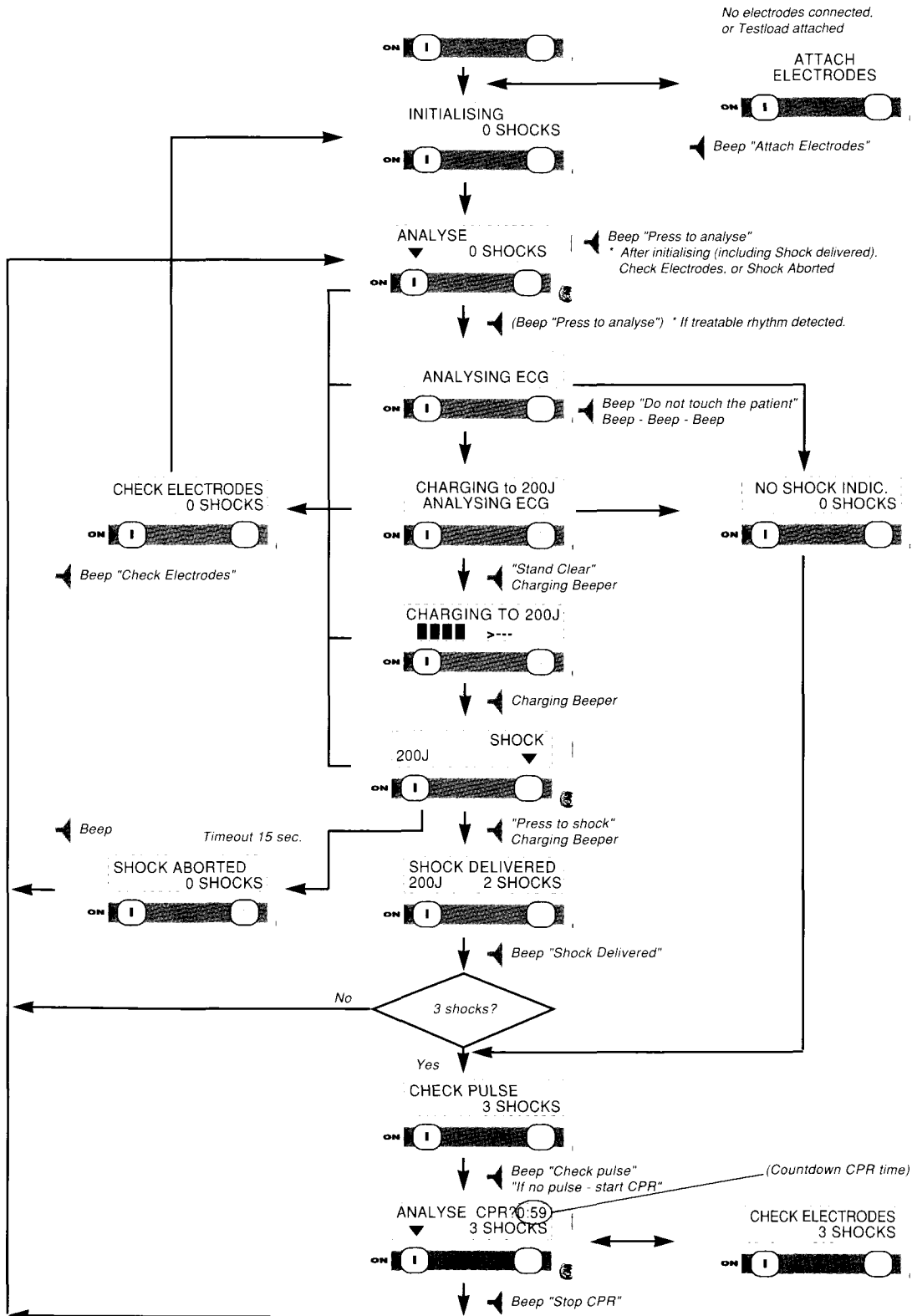

5.4.1 Cautions before turning the device on

The operator should not turn on the Heartstart 911 unless cardiopulmonary arrest has been determined, as indicated by absence of consciousness, breathing and pulse.

ECG analysis starts when the Analyse  button is pressed and the electrodes are properly attached. Artifact from CPR or patient movement may interfere with proper analysis.

5.4.2 Turn device power ON

Press the  button until a beep is heard. The device performs a selftest that lasts about 3 seconds. If the selftest detects no failures, the "SELFTEST OK" message is displayed. Otherwise a Warning or Service Mandatory message will be displayed. See Device warnings during operation, section 5.5.



If the electrodes have not been attached to the patient when the device is turned on, the "ATTACH ELECTRODES" message is both displayed and spoken. The voice message is repeated every 15 seconds.

If the "ATTACH ELECTRODES" display message remains after the electrodes have been attached, try applying pressure to the center and edges of both electrodes to improve contact. Do not try to remove and re-use the single patient use electrodes; if the message still remains, remove the electrodes and attach a new set.

After a valid electrode connection is detected, "ANALYSE" is displayed with the arrow pointing to the  button.

Note: The device turns itself off automatically if the electrodes are not attached or the "ATTACH ELECTRODES" message remains for more than 2 minutes.

5.4.3 Analysing ECG

"ANALYSE" is displayed with an arrow pointing to the  button. The voice message "PRESS TO ANALYSE" is also given. Pressing the  button initiates an analysis of the patient's ECG.

Even if the  button is not pressed, the device continuously monitors and analyses the patient's ECG. If a potentially treatable rhythm is detected, another voice message "PRESS TO ANALYSE" is given after approximately 15 seconds and repeated every 30 seconds.

Note: The "PRESS TO ANALYSE" voice message is an alert to the operator to reassess the patient. The operator should not activate the Analyse function until cardiopulmonary arrest, indicated by absence of consciousness, pulse and breathing, has been determined.

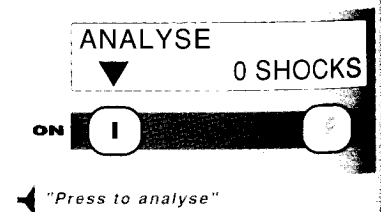
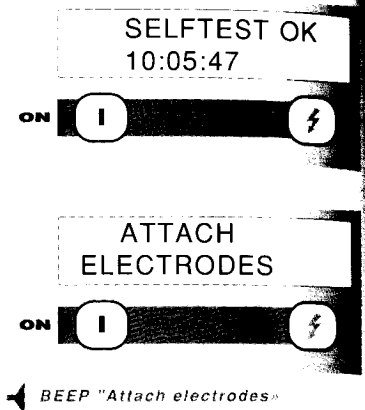

Additional "PRESS TO ANALYSE" voice messages will not occur if the patient's rhythm changes from a non-treatable rhythm to asystole, since asystole is not identified by the analysis system as a treatable rhythm.

Artifact from CPR and patient movement may cause the "PRESS TO ANALYSE" voice message to occur intermittently as well.

The voice warning "DO NOT TOUCH THE PATIENT" warns the operator that ECG is being analysed. DO NOT TOUCH OR MOVE THE PATIENT, since this may affect the analysis.

During ECG analysis, the device generates several warning beeps and displays the "ANALYSING ECG" message. The ECG analysis takes 6 - 9 seconds.

The ECG analysis results in either:

- "NO SHOCK INDIC." (No shock indicated) display message if a non-treatable rhythm was detected, followed by the "CHECK PULSE" message. See Check pulse, section 5.4.6.
- Begin charging and display the "CHARGING TO xxxJ" message if a treatable segment was detected.

5.4.4 Charging for shock

DO NOT TOUCH THE PATIENT.

The "STAND CLEAR" voice message warns the operator when high voltage may be present.

During charging, the ECG analysis outcome results in either:



- "CHARGING TO xxxJ" and the charging bar displayed if the rhythm was finally determined to be treatable, and continuation of charging.
- "NO SHOCK INDIC." display message if the rhythm was finally determined to be non-treatable, and termination of charging.

Shock energy is selected automatically.

During charging the device generates a continuous tone of increasing frequency.

Charging to full energy usually takes 10 – 15 seconds (for a 360 joule charge) and may be slightly longer in cold temperatures or if the battery is not fully charged.

5.4.5 Shock delivery

When the device reaches full charge the voice message "PRESS TO SHOCK" is given and the display indicates "SHOCK" with an arrow pointing to the  button. Clear the patient area before pressing the  button to deliver the shock.

If the  button is not pressed within 15 seconds, the energy is discharged internally and the device displays "SHOCK ABORTED" followed by the "ANALYSE" display message and "PRESS TO ANALYSE" voice message. See Analysing ECG, section 5.4.3.

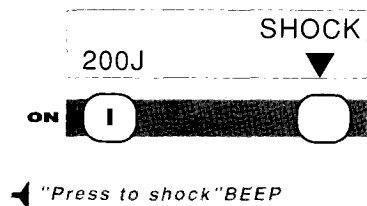
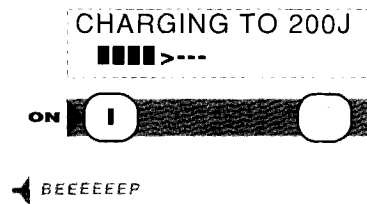
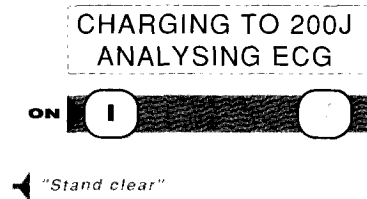
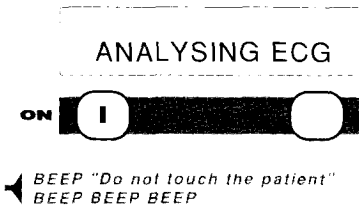

The  button is active and may be used at anytime to abort a charge, disarm and switch OFF the device.

After the shock, the "SHOCK DELIVERED", shock energy and shock count messages are displayed and the voice message "SHOCK DELIVERED" is given. An initialising period follows the shock.

If less than three consecutive shocks have been delivered, the device displays "ANALYSE" and the voice message "PRESS TO ANALYSE" is given, prompting the operator to reassess the patient for breathing and pulse. See Analysing ECG, section 5.4.3.

5.4.6 Check pulse

After 3 consecutive shocks or a "NO SHOCK INDIC." message, the device displays and gives the voice message "CHECK PULSE". After a period of 7 seconds this is followed by the "IF NO PULSE - START CPR" voice message.

5.4.7 If no pulse - start CPR

The device will display "CPR?" with a 60 second timer that counts down to zero.

ECG analysis is inactive while "CPR?" is displayed. ECG analysis may be activated during this period by pressing the  button, if appropriate. See Analysing ECG, section 5.4.3.

5.4.8 Stop CPR and analyse

When the "CPR?" period has timed out, the device gives the voice message "STOP CPR", and continues to display the "ANALYSE" message.

ECG analysis may be activated by pressing the  button.

Even if the  button is not pressed, the device continuously analyses the patient's ECG. If a treatable rhythm is detected the voice message "PRESS TO ANALYSE" is given after approximately 15 seconds and repeated every 30 seconds.

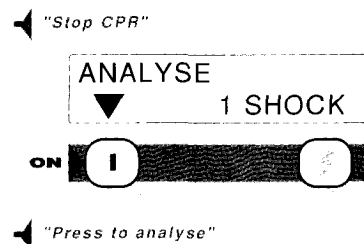
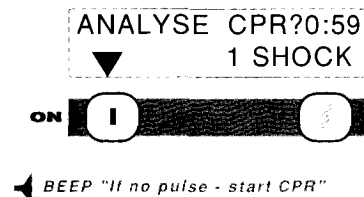
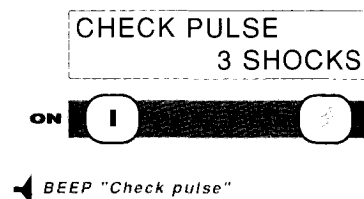
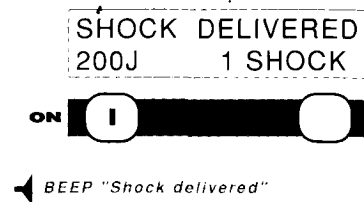

5.4.9 CHECK ELECTRODES message during operation

If improper electrode contact is detected during operation, "CHECK ELECTRODES" is displayed and a voice message is repeated every 15 seconds.

Normal device operation is suspended while

"CHECK ELECTRODES" is displayed.

Check to see if the cable is connected to the electrodes and the electrodes are properly attached to the patient.

See sections 5.3.2 and 5.3.3.

If the "CHECK ELECTRODES" interrupts ECG analysis, the device will not prompt for ECG analysis until the electrode problem is corrected. When the check electrode problem is corrected, follow the device prompts to continue device operation.

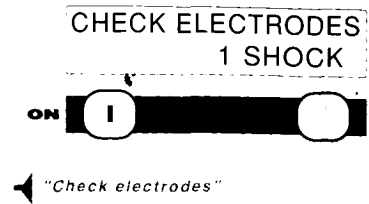

5.4.10 Device power off

The device is turned off by pressing the  button. This button is always active. Turning the device off also

aborts any charge, disarms the device and displays the "UNIT DISARMED" message before power is turned off.

The device will also automatically turn itself off if there have been no buttons pressed or changes in the electrode connection for thirty minutes. The message "AUTO OFF" will be displayed before power is automatically turned off.

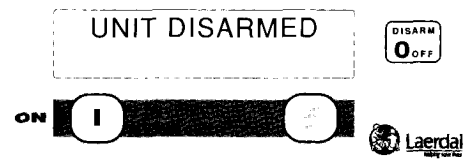

5.4.11 After-use checks, maintenance and data retrieval

Following each usage the battery should be recharged, see Battery charging, section 7.1.3.

The Heartstart 911 should be restocked, cleaned and maintained. Incident information can be retrieved using an optional MCM Plus (see sections 5.6.2 and 6.2).

5.5 Device warnings during operation

5.5.1 Battery low

A "BATTERY LOW" warning is given when the remaining battery capacity is approximately 4 shocks. The remaining capacity may vary due to battery age, maintenance, and temperature and should not be fully relied on.

The "BATTERY LOW" message remains for approximately 2 seconds, then the normal display is shown with a blinking battery symbol in the lower right corner. Thereafter the "BATTERY LOW" message is displayed for one second every 10 seconds. Operation may continue, but if possible, replace the battery with one that is fully charged and recharge the depleted battery. See Battery charging, section 7.1.3.

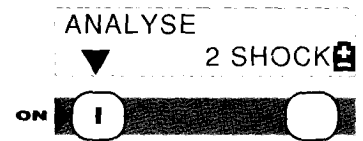
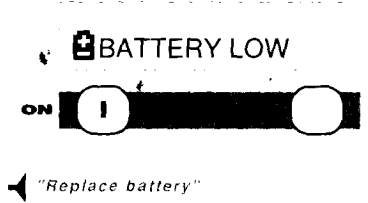

5.5.2 Replace battery warning

If three more charge to shock cycles are initiated after the "BATTERY LOW" warning, a "REPLACE BATTERY" warning will be given. The warning is given both on the display and as a voice message.

"REPLACE BATTERY" indicates that there may not be enough capacity in the battery to deliver another shock. The "REPLACE BATTERY" display message remains for approximately 2 seconds, then the normal display is shown with a blinking battery symbol in the lower right corner. Thereafter the "REPLACE BATTERY" display message is shown for one second every 10 seconds. The voice message is repeated every 15 seconds. Operation can continue, but may result in the device turning itself off (see Replace battery mandatory, section 5.5.3). If possible, replace the battery with one that is fully charged and recharge the depleted battery. See Battery charging, section 7.1.3.

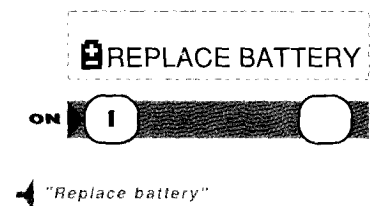

5.5.3 Replace battery mandatory

If the battery voltage goes below safe operating levels, or no analysis has been performed in the last 10 minutes following a "BATTERY LOW" or "REPLACE BATTERY" warning, the device turns itself off automatically.

"AUTO OFF" is displayed for approximately 2 seconds and the voice message "REPLACE BATTERY" is given before the device turns off. Replace the battery with one that is fully charged and recharge the depleted battery as soon as possible, see section 7.1.3.

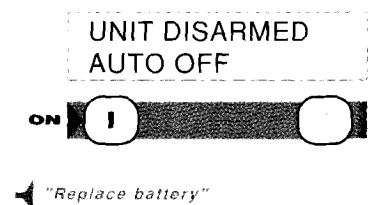

5.5.4 Service warnings

The Heartstart 911 performs a selftest each time the device is turned on. The Heartstart 911 also continuously monitors its status. If a fault is detected, a service warning is displayed with an accompanying two-tone beep. The service warning consists of a displayed service symbol (a wrench) and identifying text.

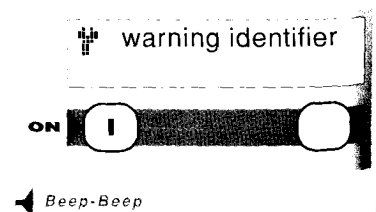

Note: Operation may continue after a service warning. If you are attempting to resuscitate a patient, use another device if available. If another device is not available, treatment with this device should continue unless there is an obvious patient or user hazard. If there is an obvious patient or user hazard, immediately discontinue using the Heartstart 911.

The service warning remains on for two seconds, then the normal display is shown with the blinking service symbol in the upper right corner. The service warning is displayed for one second every 10 seconds. Note any service warning codes and report all warnings to qualified service personnel.

Service warnings are also reported to the MCM Plus and the Internal Memory.

Refer to the section 8 for a complete list of device warnings and mandatory messages.

5.5.5 Service mandatory messages

If the Heartstart 911 detects a fault that makes the device unable to treat or may present a hazard to the patient or the operator, a "MANDATORY" message is displayed accompanied by a continuous beep. Service mandatory messages are also reported to the MCM Plus and the Internal Memory. The device is now inoperable (only the  button is active). The device will automatically turn itself off after 2 minutes.

Note: If you are attempting to resuscitate a patient, use another device if available. If another device is not available, you may continue to use this device provided there is not an obvious patient or user hazard. Turn the device off and replace the battery if another battery is available. Then turn the device on and attempt to continue treatment. If the Service Mandatory message recurs the device should immediately be taken out of service. If there is an obvious patient or user hazard, immediately discontinue using the Heartstart 911 and restart basic life support.

Make note of the service mandatory code and send the device to qualified service personnel for repair. Refer to the section 8 for a complete list of device warnings and mandatory messages.

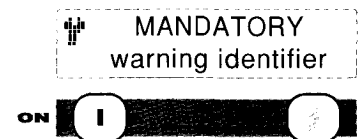
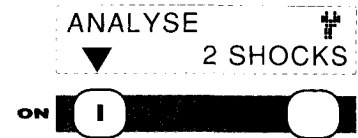

 Beep-Beep

5.6 Medical control

The Heartstart 911 has two methods for recording incident information:

- Internal Memory
- Optional Medical Control Module Plus (MCM Plus)

5.6.1 Internal memory

An event log and up to 150 seconds of prioritised ECG are automatically stored in the Heartstart 911 Internal Memory when the device is turned ON and connected to a patient. The contents of the Internal Memory can be downloaded into an MCM Plus (see DOWNLOAD, section 6.2). The data in the MCM Plus can be printed by a Laerdal MCM reporting device.

Note: A stairstep, squarewave ECG segment may be inserted during the download to enable the shock records report to occur if ECG memory is full. This stairstep wave ECG is not patient data.

The contents of Internal Memory are automatically cleared when the Heartstart 911 is turned on and connected to a patient, if more than 24 hours has elapsed since the last use, or if the contents have been downloaded to an MCM Plus. The contents of Internal Memory can also be cleared manually (see MCM-CLEAR, Section 6.1)

If the Internal Memory becomes full during use, a "INT. MEM. FULL" warning appears on the display. No further data is logged in Internal Memory until the memory has been cleared or downloaded.

5.6.2 Medical Control Module Plus semiautomatic (MCM Plus')

Events and up to 20 minutes of ECG can be stored in a semi-automatic MCM Plus when the device is turned on and connected to a patient.

Note: A manual MCM Plus will allow ECG and event data to be recorded, but will not cause the Heart-start 911 to operate in manual mode. HEARTSTART 2000 MCMs will not allow ECG or event data to be recorded.

Installation

The module is installed on the left side of the Heartstart 911. Insert the MCM Plus firmly until it is fully seated. Before use, make sure the MCM Plus is cleared and made ready for use. This can be done either in the reporting devices or in the Heartstart 911 itself. (see section 6.1)

10 : 21 : 27

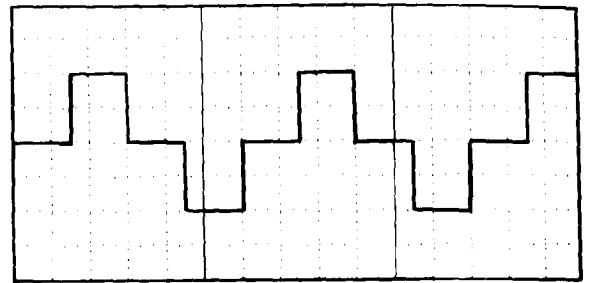

SHOCK
DELIVERED

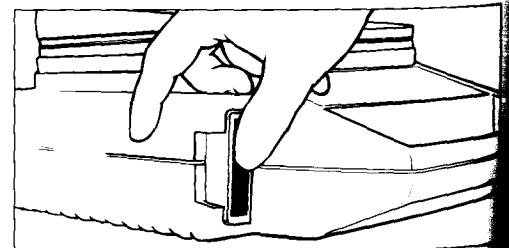

Printing MCM Report

After an event, and in accordance with procedures for review, remove the MCM Plus by pulling it outwards from the receptacle. A report can be printed using one of the following Laerdal reporting devices: Heartstart Reporter, Quick Reporter-Charger, or Heartstart 3000QR. For details, see the operating instructions for the appropriate device.

Refer to Medical control in section 8, for a list of the annotations and data which will be reported from the MCM Plus.



Warnings

If the MCM Plus becomes full during use, a "MCM FULL" warning appears on the display. No further event data is logged in the MCM Plus until it has been cleared.

Note: The device will still operate normally even if the MCM or Internal Memory are full. This does not prevent the device from treating the patient.

The MCM Plus contains a battery which may require replacement after approximately 5 years. If the warning "MCM BATT. LOW. " appears on the display, the MCM Plus may not maintain stored data. Return the MCM Plus to Laerdal service for battery replacement.



6. SETUP FUNCTIONS

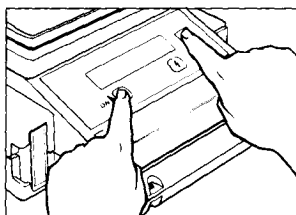

Setup allows the user to set or view parameters associated with device operation. Setup is entered from the power OFF state by turning the device on with the  button while pressing the  button. Setup allows the operator to select the desired setup function from a top level main menu. The device then displays the sub menu for that function.



When Setup is entered the first function of the main menu is displayed. The main menu contains these 7 functions:

| | |
|-----------|--|
| MCM-CLEAR | Clears Internal Memory and MCM Plus |
| DOWNLOAD | Transfers Internal Memory contents to an MCM Plus. |
| CLOCK | Used to set the device clock time and date. |
| VOLUME | Used to set the volume of the voice messages. |
| VERSIONS | Displays the device software parameters. |
| AUTO-TEST | Used to enable/disable the device auto selftest. |
| SELFTEST | Used to manually start the auto selftest. |

The main menu always displays an arrow labeled "NEXT" pointing to the  button and an arrow labeled "SELECT" pointing to the  button. Pressing the "NEXT" button displays the next function in the main menu. The main menu loops back to the MCM CLEAR function after the SELFTEST function. Pressing the "SELECT" button enters that function and changes the display to the sub menu for that function.

To leave Setup, press the  button when any of the main menu functions are displayed. The device saves any changes made while in Setup and turns itself off. If a function has been selected and the sub menu is being displayed, pressing the  button exits the sub menu and returns to the main menu. Pressing the  button a second time saves any changes, exits Setup, and turns the device off.

6.1 MCM-Clear

This function prepares an MCM Plus and the Internal Memory for reuse and resets the shock counter. The contents are not actually changed until the device is turned on again with the electrodes connected to a patient.

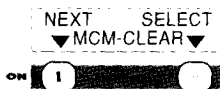

- Enter Setup.
- Press the "SELECT" button to enter the MCM-CLEAR function.



- Press the "CLEAR" button to start the MCM CLEAR function.

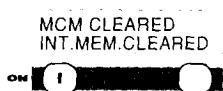

There are two possible displays at the end of the MCM CLEAR function.

- If the "CLEAR" button is pressed with an MCM Plus installed, both the MCM and Internal Memory are cleared. Completion of the clear function is shown on the display for 2 seconds, followed by a return to the main menu function.
 
- If the "CLEAR" button is pressed without an MCM Plus installed, only the Internal Memory is cleared. Completion of the clear function is shown on the display for 2 seconds, followed by a return to the main menu function.
 

Press the "CANCEL" button or the  button to return to the MCM-CLEAR main menu.

6.2 Download

This function downloads the contents of the device Internal Memory into an MCM Plus. The transferred data in the MCM Plus can then be printed using a Heartstart Quick Reporter/Charger, Heartstart Reporter or Heartstart 3000QR.

- Install an MCM Plus in the device.
- Enter Setup.
- Use the "NEXT" button to advance to the DOWNLOAD function.
- Press the "SELECT" button to enter the DOWNLOAD function.



- Press the "CANCEL" button or the  button to return to the DOWNLOAD main menu without doing the download.
- Press the "DOWNLOAD" button to start the download function.

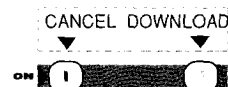

If the MCM used contains data which has not been reported, the display is as shown.

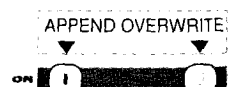

- Pressing the "APPEND" button causes the data from the Internal Memory to be added to the end of the existing MCM data.

- Pressing the "OVERWRITE" button clears the MCM Plus and overwrites the MCM Plus memory with data from the Internal Memory.

- At completion of the download, the display is as shown and remains for 2 seconds, followed by a return to the DOWNLOAD main menu.



- If the MCM Plus does not have enough memory to append the entire download data from the Internal Memory, the display is as shown and remains for 2 seconds, followed by a return to the DOWNLOAD main menu. The MCM Plus may not contain all the data in the Internal Memory. To get all the data, "OVERWRITE" may be required.



There are 2 possible displays if the DOWNLOAD function is not possible.

- If there is no internal data to be downloaded to the MCM the display is as shown and remains for 2 seconds, before returning to the DOWNLOAD main menu.

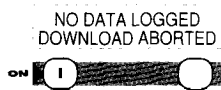

- If an MCM Plus is not installed, the display is as shown and remains for 2 seconds, before returning to the DOWNLOAD main menu.



6.3 Clock

The clock function is used to set the time and date maintained by the device's clock. The clock is a 24 hour clock. The seconds are reset to zero when leaving this function.

- Enter Setup.
- Use the "NEXT" button to advance to the CLOCK function.

- Press the "SELECT" button to enter the CLOCK function.

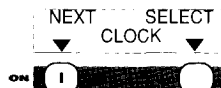

Press the "ADVANCE" button to increment the highlighted (blinking) clock segment. If the "ADVANCE" button is held the device goes to fast increment.

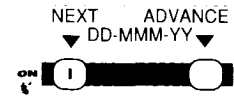

DD = day of the month
 MMM = month of the year
 YY = year
 hh = hour of the day
 mm = minute of the hour

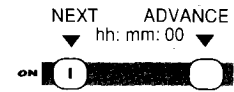

- Press the "NEXT" button to advance the highlighted (blinking) clock segment one position.
- Press the button at any time to save the new setting, display the current date and time, and return to the CLOCK main menu.

6.4 Volume

The speech volume can be set to low, medium, or high. The volume of the beeper is not affected by the speech volume setting.

- Enter Setup.
- Use the "NEXT" button to advance to the VOLUME function.
- Press the "SELECT" button to enter the VOLUME function and display the current volume setting. Three volume settings can be selected.



LOW

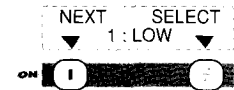

MEDIUM

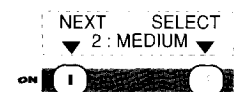

HIGH

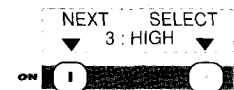

- Press the "SELECT" button to hear the voice message "STOP CPR" at the displayed volume.
- Press the "NEXT" button to advance to the next volume setting.
- Press the button at any time to save the displayed setting and return to the VOLUME main menu.

6.5 Versions

This function displays the following information pertaining to the installed software:

- Main software version, revision level and the language code.
- Energy levels for the 3 shock sequence.
- I/O software version and revision level.
- Calibration table version and revision level, and the selected calibration group.
- Total number of shocks the device has delivered.

Enter Setup.

- Use the "NEXT" button to advance to the VERSIONS function.
- Press the "SELECT" button to enter the VERSIONS function.



Note: This information cannot be revised by the operator.

Once the VERSIONS function has been entered, the data is displayed sequentially. The display advances to the next display each time the "NEXT" button is pressed.

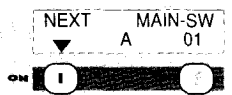

Where: A = software version.
01 = US language code or
02 = British, etc.



Analysis configuration.
200-200-360 = three shock
energy sequence

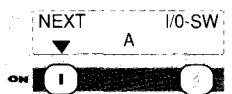

Where: A = software version

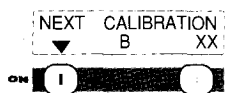

Where: B = version of the
calibration table.
XX = selected calibration
group [1-15].

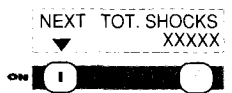

Where: XXXX = Total number
of shocks delivered over the
life of the device.

- Press the button at any time to return to the VERSIONS main menu.

6.6 Auto-test

This Setup function can be used to enable or disable the automatic **wakeup** selftest and define the hour for the start of the test. It does not affect the regular selftest performed when the device is turned on by the operator, or the self-test performed when the device is connected to a charger or the selftest activated through the selftest setup menu.

- Enter Setup.
- Use the "NEXT" button to advance to the AUTO-TEST function.

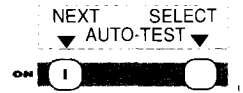

- Press the "SELECT" button to enter the AUTO-TEST function.



- Display if previous AUTO-TEST selection was enabled.



- Display if previous AUTO-TEST selection was disabled.

- Pressing the "NEXT" button causes the display to change to the other display.

- Pressing the button or "SELECT" button when "DISABLED" is displayed leaves AUTO SELFTEST disabled and returns to the AUTO-TEST main menu.

- Pressing the button when "ENABLED" is displayed leaves AUTO SELFTEST enabled and returns to the AUTO-TEST main menu.

- Pressing the "SELECT" button when "ENABLED" is displayed enters the sub menu to set the time for the auto selftest.

- Press the "ADV." button to change the hour when the AUTO SELFTEST is performed.

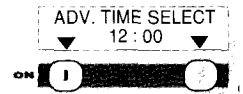

- Press the "SELECT" or the button to save the time displayed and return to the AUTO-TEST main menu

6.7 Selftest

This function is used to manually activate the Automatic Selftest. If the device detects an error it displays the warning code and the device remains on and beeps periodically (see Automatic selftest check, section 7.3).

- Enter Setup.
- Attach the patient cable to the test load.
- Use the "NEXT" button to advance to the SELFTEST function.

- Press the "SELECT" button to enter the SELFTEST function.



- Press the "CANCEL" button or  button to return to the SELFTEST main menu.



- Press the "ACTIVATE" button to start the auto selftest. The voice message "STAND CLEAR" will be spoken before the low energy shock is automatically delivered.

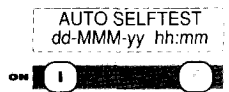

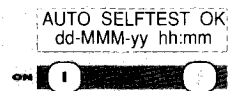

Warning! Do not touch the test load or the patient cable during this test

At completion of the selftest, the device displays the status, time, and date of the test for 5 seconds before powering OFF. The Internal Memory will be updated with the results of the auto selftest. If the previous memory entry indicates auto selftest was OK then it will be overwritten with the latest auto selftest results.

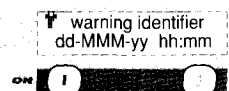

If an error is detected, the error code is displayed, and the device remains ON and beeps periodically (see section 7.3).



If the device is turned off with the  button during test, the selftest is aborted.

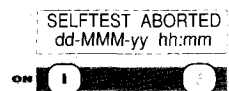

7. MAINTENANCE

7.1 Battery installation, charging and care

Battery maintenance is extremely important to ensure the Heartstart 911 operates reliably.

Periodically check the battery to assure the recommended replacement date has not elapsed. Expired batteries should be disposed of per local regulations or returned to an authorized service center.

Always charge the battery for a minimum of 16 hours to return the battery to full capacity.

Maintain the battery during recharging between 5°C and 40°C.

Note: Use only Laerdal approved battery charger.

7.1.1 Battery installation

- Grasp the fully charged battery with the metal contacts facing towards the receptacle and the beveled edge down.
- Slide the battery into the receptacle as illustrated, ensuring that it seats fully and that the latch snaps into place to hold the battery in the device.
- A second fully charged battery should be carried in the storage pouch.

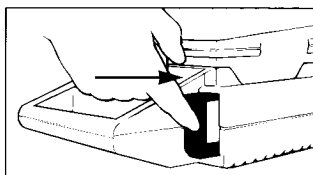

7.1.2 Battery removal

Press the battery eject button. The battery is partially ejected, allowing it to be removed from the device.

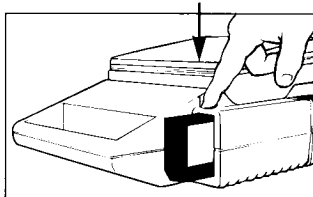

7.1.3 Battery charging

The battery can be left on continuous charge when it is not in use. The Heartstart battery can be charged in one of three ways:

- Connect the Heartstart 911 with installed battery to the Storage/Charging rack. Battery status is indicated by the rack's battery charger. (A spare battery can be maintenance charged, trickle charge only, in the separate battery adapter. Batteries placed into the maintenance adapter need to be fully charged first).
- Connect the Heartstart 911 with installed battery to the Heartstart battery charger. Battery status is indicated by the battery charger.

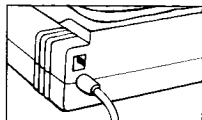
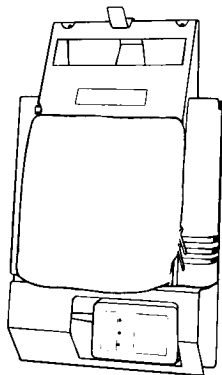

It is recommended that the battery charger is not connected during device operation. The battery charger cannot give sufficient power to operate the device, battery must always be installed.

- Install individual battery in the battery charger adapter.



Battery charger indicators:

- POWER (green indicator) indicates the battery charger is correctly connected to the AC mains supply. This indicator should always be lit.
- FAST (yellow indicator) indicates the battery is being charged in the fast charge mode. Do not use the battery being charged if the FAST charge indicator is lit.
- TRICKLE (orange indicator) indicates the battery is being charged in trickle charge mode. The battery has been recharged to approximately 80% capacity when the TRICKLE indicator is first lit. The battery can be used at this time. However, 16 hours of charging is recommended to ensure a complete recharge and optimum battery performance. For detailed battery charger instructions, see the appropriate operating instructions for the battery charger.

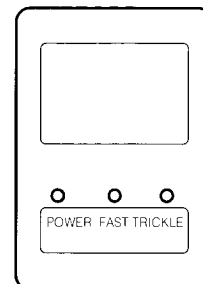

7.1.4 Some advice to keep your Heartstart 911 batteries in good condition

- Recharge the battery after each use. Use only Laerdal approved batteries and recharge them for a minimum of 16 hours to assure a complete recharge.
- Keep the Heartstart 911's installed battery on continuous charge. If the charger is not connected, ensure maintenance charging of the battery at regular intervals. Recharge batteries that have not been used in the Heartstart 911 at least once every 6 months.
- Do not wait for the "BATTERY LOW" or "REPLACE BATTERY" display messages to appear before recharging your batteries.
- If the Heartstart 911 is not kept on continuous charge, keep two fully charged batteries in service; one in the device and a spare in the pouch or in the maintenance charge adapter (charging rack). If the Heartstart 911 is kept on continuous charge, make sure the spare battery is fully charged. Batteries stored in device and maintenance charge adapter should be interchanged every 6 months if device is not used.
- If the Heartstart 911 is to be used frequently, additional batteries and/or battery chargers may be required.
- Laerdal recommends that batteries be replaced every 2 1/2 years if batteries are to be properly maintained.

7.1.5 Battery capacity test

- Battery capacity should be tested at least once every six months by delivering fifteen consecutive shocks into a Heartstart Tester or equivalent, at room temperature. If a fully charged battery cannot deliver fifteen shocks before a battery warning message is displayed, it should be taken out of service and replaced. Marking the batteries with the date when capacity was last checked will help track this activity.
- Replace the Heartstart battery if it does not meet the above capacity test, or when the recommended replacement date has elapsed.
- Heartstart Battery Tester may be used as an alternative. See separate operating instruction.

7.2 After-use and periodic checks

After each use the Heartstart 911 needs to be examined and restocked in preparation for its next use. Any incident information should be retrieved and printed using the MCM Plus and an external reporting device. Simple checks of the device's status, supplies and functionality are recommended after each use.

Periodically a more detailed test of the Heartstart 911's operation and battery status should be performed.

A check list is provided to assist in these after use and periodic checks. (See Appendix A&B.)

The Heartstart 911 has an automatic selftest feature which will daily test the device's functionality and check its status. The Heartstart 911 must be connected to a Heartstart charger, either directly or through the Storage/Charging rack, before the automatic selftest can be used. If the automatic selftest feature is not enabled, the Heartstart 911 must be manually cycled through the selftest to test its functionality.

In some applications different shifts of personnel routinely check vehicle equipment and supplies at shift change. The Heartstart 911 device should also be inspected at that time.

7.3 Automatic selftest check

The automatic selftest checks the device's functions by charging and automatically delivering a low-energy shock into the testload attached to the patient cables in the cable storage compartment. To pass the test, the electrode cables must be connected to the testload.

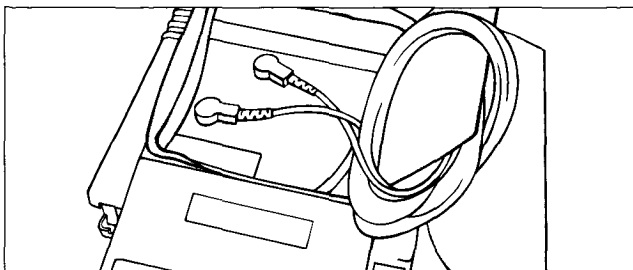

The automatic selftest is performed every time the Heartstart 911 is connected to the Heartstart charger directly or through insertion in the Storage/Charging rack.

The automatic selftest may also be performed once every 24 hours at a programmable time of day, as long as the device is connected to the Heartstart charger and a battery is installed. This automatic wake-up function can be enabled or disabled using the Setup function (see section 6.6).

The date, time and "AUTO SELFTEST OK", or error message remains on the device's display after the test has been performed and as long as the device is connected to the charger. The results of the last selftest are also stored in Internal Memory and the MCM Plus, if installed.

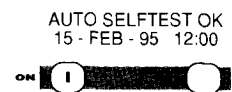

If an error is detected during the automatic selftest, the device will not turn itself OFF, but remains on and gives a beep tone every 5 seconds. The error is indicated on the display. The error is also stored in Internal Memory and in the MCM Plus, and is shown at the top of the event-log when a report is printed.

If an error is indicated, refer to Trouble-shooting, section 9, to resolve it.

7.4 Device Cleaning

If blood or other body fluids are present, they must be removed and the device disinfected per local cleaning and handling procedures. Clean the device noting the following precautions:

- Remove the batteries, electrodes, and MCM Plus, and other accessories from the device before cleaning.
- Use a mild, non-abrasive soap or cleaner to clean the exterior parts of the defibrillator, pouch or soft pack.
- All spills of blood and blood-contaminated fluids should be promptly cleaned up using an EPA-approved germicide or a 1:100 solution of household bleach.
- Use care not to scratch the protective display window.
- Do not spray liquid cleaning agents directly on the defibrillator. Spray them on a soft cloth or towel and then use it to wipe the device clean.
- Do not immerse the device or any parts of the device in water or any other solution.
- Do not sterilize the device or electrodes.
- Allow the device to air dry before use.

7.5 Device maintenance

It is recommended the Heartstart 911 should be sent to qualified service personnel annually to have the ECG acquisition and energy delivery sections checked.

8. SPECIFICATIONS

General

The Heartstart 911 is designed and built to comply with:

| | |
|-------------|--|
| AAMI DF39 | "Automatic external defibrillators and remote control defibrillators." |
| IEC 601 | "Safety of medical electrical equipment." |
| IEC 601-2-4 | "Particular requirements for the safety of cardiac defibrillators and cardiac defibrillator monitors." |
| AAMI DF-2 | "Cardiac defibrillator devices" |

Physical properties

| | |
|---------|---|
| Weight: | < 4 kg including battery |
| Size: | 351 x 275 x 101 mm (length x weight x height) |

ECG input

ELECTRODES:

| | |
|--------------------------|---|
| Type | Self-adhesive disposable defibrillation electrodes per AAMI DF-39 |
| Storage Temperature | 15 - 35°C recommended, -13 to 43°C maximum |
| Electrode placement | Red to Apex, White to Sternum, modified lead II configuration |
| Patient contact material | Conductive polymer |
| Contact area size | 65 cm ² minimum, 150 cm ² minimum per pair |
| Shelf life | minimum 1 year from shipping date to expiration date |
| Patient cable, length: | 2.3 m ±0.3 m |

ECG:

| | |
|-----------------------|------------------------------|
| Bandwidth | 1.5 – 27 Hz to –3 dB nominal |
| Noise rejection | >30 dB at 50 Hz and 60 Hz |
| Common mode rejection | >45 dB at 50 Hz and 60 Hz |
| Digital sampling rate | 100 ± 1 samples / second |

ECG FRONT END:

| | |
|------------------------------------|--|
| Protection, Energy absorption | Against 5 kV 360 J DC shocks <10% loss with a 100 Ω load |
| Leakage currents, Normal Operation | Comply with IEC-601 Type BF |

| | |
|-----------|--|
| Isolation | From input to conductive touchable parts: 4 kV min. Comply with IEC-601-2-4 |
|-----------|--|

ECG rhythm recognition detector

TREATABLE ECG:

| | |
|--------------------------|-----------------------|
| Ventricular Fibrillation | amplitude ≥200 μV p-p |
| Ventricular Tachycardia | QRS rate ≥180 b.p.m |

| | |
|-----------------|------|
| Specificity: | >95% |
| VF Sensitivity: | >90% |
| VT Sensitivity: | >75% |

| | |
|------------------------------|---|
| Maximum analysis time: | 9 seconds |
| Shock criteria: | 6 out of 9 seconds of ECG determined treatable |
| "PRESS TO ANALYSE" criteria: | 9 out of 12 seconds of ECG determined treatable |

Electrode connection

| | |
|----------------------------|--|
| Measurement frequency: | 2 kHz ±20 Hz |
| Limits for shock delivery: | |
| Shorted electrodes: | no treatment possible |
| Open electrodes: | no treatment possible |
| Defibrillation electrodes: | treatment enabled |
| ECG monitoring electrodes: | Cannot connect to monitoring electrodes |
| Disconnected electrodes: | After the device is powered on the device turns itself off after 2 minutes if no electrode connection has been detected. |

Defibrillation circuit

Typical patient waveforms

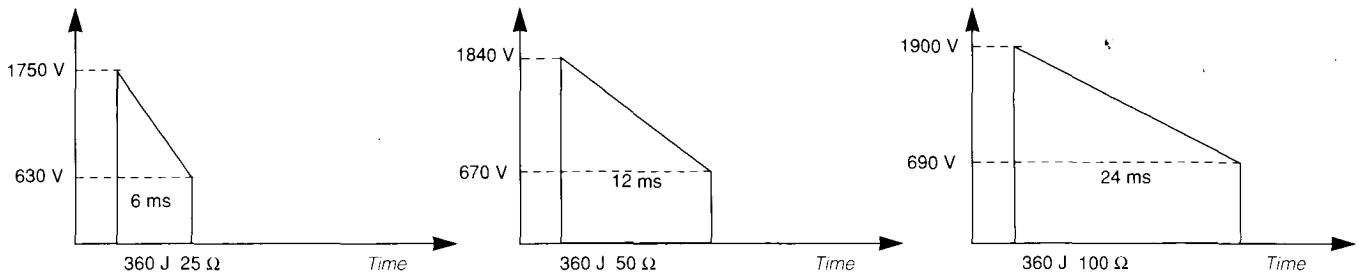

| | |
|---|---|
| Waveform type | Truncated exponential per AAMI/ANSI DF-2-1989 |
| Available energies | 200J, 300J, 360J |
| Energy accuracy: | |
| 50 Ω | ± 15% |
| 25 Ω - 200 Ω | ± 30% |
| Internal voltage, maximum: | 2350 VDC nominal |
| Discharge times 360 J: | per AAMI DF-39 and AAMI DF-2 |
| 25 Ω | 15 milliseconds maximum |
| 50 Ω | 24 milliseconds maximum |
| 100 Ω | 40 milliseconds maximum |
| Capacitor bank, Nominal: | 220 μF, 2250 V |
| Charging time to 360 J: | 10 seconds nominal with new fully charged battery 15 seconds nominal after 15 maximum energy discharges. |
| Charging time-out: | 20 seconds maximum from start of charge |
| Shock delivery time-out: | 15 seconds from charge complete, until charge is internally discharged |
| Endurance: | 10,000 shocks or 8 years, whichever comes first |
| Max. number of shocks per hour at 50°C: | 50, with minimum of 1 hour rest between sequences |
| Max. number of shocks per week: | 1000 |
| Shock polarity: | Positive: red electrode Negative: white electrode |
| Test Load: | 100 ± 5 Ohms, nominal |

Treatment protocol

| | |
|---------------------------------|---|
| Energy selection: | 200 J - 200 J - 360 J |
| Patient shock counter is reset: | When device is turned OFF for more than one hour since last shock was delivered, or, when MCM Plus is cleared, or Internal Memory is downloaded |

Environmental conditions

| | |
|--|---|
| <i>Operating.</i> | |
| Temperature | 0° C to +50° C |
| Humidity | 5 % to 95% RH non condensing |
| Pressure | 700 hPa to 1060 hPa |
| <i>Storage: (excluding electrodes and batteries)</i> | |
| Temperature | -13° C to +60°C. |
| Humidity | 5 % to 95% RH non condensing |
| Pressure | 700 hPa to 1060 hPa |
| Splash proof: | IEC-529, IP code IPX4 |
| Bump: | Test in accordance with IEC 68-2-29 Severity: Bump pulse 40 g, 6 ms |
| Vibration: | Test in accordance with IEC 68-2-6 Severity: Freq./Amplitude: 10 -58 Hz: ± 0.15 mm 58-150 Hz: 2g |
| Free fall drop: | Test in accordance with IEC 601-1 subclause 21.5. 3 falls to hardwood plate from 1 m. |







Electromagnetic Compatibility Requirements: Comply with AAMI DF-39 and IEC 601-1-2.

Expected life and maintenance

Expected life from production date:

| | |
|-----------------------------------|---|
| HEARTSTART-911 device: | 8 years, provided regular preventative maintenance is performed and components with lower life expectancy are replaced. |
| Replacement components: | |
| Clock battery: | 5 years |
| MCM Plus battery: | 5 years |
| Capacitors: | 8 years or 10,000 shocks |
| Heartstart 911 battery: | 2 1/2 years |
| Preventive maintenance intervals: | 1 year recommended |

Symbols used

| | |
|---|---|
|  | Warning and indication |
|  | Battery low |
|  | Refer to operating instructions |
|  | Type BF in accordance with IEC-601, defibrillation protected |
|  | High voltage |
|  | Date of manufacture |
|  | Product is in compliance with essential requirements of council directive 93/42/EEC: Medical Device Directive |

Controls, during operation

| | | |
|--------------|---|--------------------------------------|
| ON |  | Turns power ON, starts ECG analysis |
| Shock |  | Delivers shock when device indicates |
| OFF/DISARM |  | Turns device OFF and aborts shock |
| Display type | | LCD character display with backlight |

Voice messages

| | |
|---------------------------|----------------------------|
| "ATTACH ELECTRODES" | "CHECK ELECTRODES" |
| "PRESS TO ANALYSE" | "DO NOT TOUCH THE PATIENT" |
| "STAND CLEAR" | "PRESS TO SHOCK" |
| "SHOCK DELIVERED" | "CHECK PULSE" |
| "IF NO PULSE - START CPR" | "STOP CPR" |
| "REPLACE BATTERY" | |

Voice message volume settings: Low, medium, high

Beeper

| | |
|------------------------------------|---|
| Charging beeper: | Continuous tone, frequency proportional to capacitor voltage. |
| Beep after invalid button pressed: | Short beep. |
| Beep at error messages: | Beep. |
| "BATTERY LOW" and service warnings | Two-tone beep |
| "MANDATORY" service messages | Continuous tone for two minutes |
| Automatic Self Test Error: | Two-tone beep, repeated every 5 seconds |

Device warnings and mandatory messages

| Message | Code | Description |
|-------------|------|--|
| MANDATORY | | This message means that the Heartstart 911 requires immediate service. "MANDATORY" can apply to any warning below, except those listed as 'warning only' |
| CHARGER | 02 | Charge not reached in 20 seconds |
| I/O PROC. | 03 | Charge command timeout: I/O proc. not responding to Main proc. |
| DISCHARGE | 04 | Shock not delivered |
| ENERGY LOW | 05 | Delivered energy was low - warning only |
| ENERGY HIGH | 06 | Delivered or pre-shock charge energy was too high |
| DISCHARGE | 07 | Too long in discharge |
| DUMP RELAY | 13 | Dump relay not closed error |
| I/O PROC. | 14 | I/O error, not in monitoring state |
| COMMUNIC. | 15 | I/O download data error - warning only |

| | | |
|----------------|----|---|
| SHOCK COUNT | 16 | Hourly shock count exceeds 50 shocks - warning only |
| I/O PROC. | 17 | I/O processor not sampling on ECG channel one |
| COMMUNIC. | 21 | Communication, checksum, timeout error - warning only |
| COMMUNIC. | 22 | I/O processor halted, timeout |
| VOLT HIGH | 31 | +7V supply is too high - mandatory only |
| VOLT LOW | 32 | +7V supply is too low - mandatory only |
| VOLT HIGH | 33 | -7V supply is too high - mandatory only |
| VOLT LOW | 34 | -7V supply is too low - mandatory only |
| VOLT HIGH | 35 | +5V VCC supply is too high - mandatory only |
| VOLT LOW | 36 | +5V VCC supply is too low - mandatory only |
| RAM FAIL | 41 | RAM data error - mandatory only |
| ROM FAIL | 42 | EPROM checksum error, program memory - mandatory only |
| CPU FAIL | 43 | Main processor CPU test error - mandatory only |
| TIMER FAIL | 44 | Main processor timer failed - mandatory only |
| KEYBOARD | 45 | Shock button active at power ON - warning only |
| RTC-CLOCK | 46 | Real time clock error - warning only |
| MCM BAT.LOW | 47 | MCM internal battery is low - warning only |
| MCM FULL | | MCM Plus is full, - warning only |
| INT. MEM. FULL | | Internal MCM memory is full - warning only |
| TEST LOAD | 50 | Incorrect or no test load connected during auto selftest |
| EXT CHR9 | 52 | Bat. Charger connected at power ON - warning only |
| RTC-CLOCK | 53 | Real time clock battery is low -warning only |
| | | |
| CHARGER | 81 | Hardware overvoltage detected |
| CHARGER | 82 | Charge not reached in 22 seconds |
| CHARGER | 83 | Shock not given within 17 seconds of full charge, shock aborted |
| ENERGY HIGH | 88 | Truncation error, energy was high - warning only |
| DISCHARGE | 89 | Voltage not dropping at 40 milliseconds |
| CHARGER | 92 | Charging ratio error, HV < low limit at 2/3 seconds |
| CHARGER | 93 | Charging voltage drop detected |
| CALIBRATION | 94 | Calibration parameters checksum error - warning only |
| I/O-PROC. | 95 | I/O processor CPU test error - mandatory only |
| I/O-PROC. | 96 | I/O processor timer failed - mandatory only |
| I/O-PROC. | 97 | RAM data error - mandatory only |
| I/O-PROC. | 98 | EPROM checksum error, program memory - mandatory only |
| CHARGER | 99 | Charging ratio error, HV > high limit at 2/3 seconds |

Medical control

Events annotated in MCM Plus and Internal Memory

| Event: | Parameters annotated. |
|--|---|
| Device ON. | "UNIT ON", time/date, Device serial no., device part no. |
| If MCM is inserted after device on. | Software version "HS-911", time "MCM IN", time |
| Electrode connection checked | "DEFIB. ELECTRODES", time |
| Internal test data | "TEST= xxx", time |
| Analysis started | "START ANALYSIS", time |
| Charging started | "START CHARGING", time |
| Decision to treat | "COMMIT TO TREAT", time |
| Ready to shock | "READY TO SHOCK", time |
| Shock not indicated. | "NO SHOCK INDICATED", time |
| Shock delivered | "SHOCK DELIVERED NO. n xxxJ", time, energy, patient impedance, battery status and test data (n is shock count and xxx is energy) |
| Shock aborted | "SHOCK ABORTED", time |
| "IF NO PULSE - START CPR" message | "CPR ?", time |
| "STOP CPR" | "CPR STOP", time |
| "CHECK ELECTRODES" message given. | "Check electrodes message given", time |
| "PRESS TO ANALYSE" message given because | |
| ECG analysis finds treatable rhythm: | "ANALYSE!", time |
| ECG No Longer treatable | "Check patient cleared", time |
| Battery low warning | "BAT.LOW", time |
| Replace battery warning | "RPL.BAT", time |
| Device turns OFF because battery low | "BAT.FAIL", time |
| Service warnings | "WARN xx", time, (xx = error code) |
| Service Mandatory messages | "SM xx yy", time, (xx = error code, yy = voltage value, if failed) |
| Device off, manual | "UNIT OFF", time |
| Device off, automatic | "AUTO OFF", time |
| Download internal memory (appended) | "DOWNLOAD" at start and "DWNL END" at end of data block |
| Report from auto selftest | "SELFTEST" at start, "TEST END" at end of selftest data block, and "TEST OK" if no errors found |
| Data block separator | "-----" |
| Test shock OK | "SHOCK OK" |

ECG Storage

| | |
|-------------------------------------|---|
| Continuous ECG in MCM Plus: | 20 minutes of continuous ECG from the time the electrodes are connected and the device is powered ON After the 20 minutes of ECG memory is filled with continuous ECG, only prioritised ECG is stored. The last non-prioritised continuous ECG segments are overwritten by new prioritised ECG |
| Prioritised ECG in MCM Plus: | 20 minutes of prioritised ECG can be stored Presenting rhythm. 9 seconds from the time the device powers ON or the MCM Plus is inserted with electrodes connected Analyse and Shock. ECG from the time "ANALYSE" is activated until 15 seconds after the shock is delivered, or until no shock is indicated "PRESS TO ANALYSE". 6 seconds of ECG around the first "PRESS TO ANALYSE" message given because background analysis finds a treatable rhythm Monitoring. 6 seconds of ECG every minute when there is no other activity After the MCM Plus is filled with continuous ECG, monitoring segments are stored only every 10 minutes No prioritised ECG is overwritten in the MCM Plus When the full 20 minutes of ECG storage is filled with prioritised ECG, ECG logging and event annotation stops (MCM Plus is full) |
| Prioritised ECG in internal memory: | 150 seconds of prioritised ECG is stored in the internal memory Presenting rhythm. 9 seconds of ECG from the time the device is powered ON and electrodes connected Analyse. 9 seconds of ECG from the time "ANALYSE" is activated Shock. 12 seconds of ECG following shock delivery When the internal ECG memory is full, the last stored 21 seconds will be overwritten with new prioritised ECG |

Internal Clock/calendar

| | |
|---------------------------|-----------------------|
| Clock presentation format | 24 hour |
| Accuracy | ± 26 minutes per year |

Battery (new and fully charged)

| | |
|---------------------|---|
| Battery type | Rechargeable sealed lead-acid |
| Nominal Voltage | 12 V |
| Capacity | 2 Ah nominal |
| Temperature: | -15 to 40°C, during storage 5 to 40°C, during recharge |
| Expected life | 2 1/2 years, with proper charging and maintenance |
| Operating capacity | ≥30 360 J shocks at > 20°C for new and fully charged batteries. |
| Self-discharge rate | <54 % over 1 year at 25°C |
| Weight | 700g |
| Size | 200 x 62 x 25 mm |

Device current consumption.

| | |
|-------------------------------|---|
| Normal operation, at 12 volts | 300 mA maximum for device 50 mA maximum for tapedeck |
| During charge, at 10.5 volts | 11 A maximum |

Battery low alarms.

"BATTERY LOW" message: When capacity is approximately <4 shocks
"REPLACE BATTERY" message: When 3 charge cycles have been initiated, after
"BATTERY LOW" warning
Automatic shutoff: When nominal capacity <1 shock, or 10 minutes since "BATTERY LOW"
given, and no analysis performed, or 10 minutes since last analysis with
"BATTERY LOW" or "REPLACE BATTERY"
Time to recharge fully depleted battery: 16 Hours, minimum

Battery charger

Connectors: Charging connector
Mounting rack connector.
Charger type: Two step charger with automatic selftest power output
Fast charge: Constant current indicated by yellow "Fast charge" light.
Float charge: Constant voltage indicated by orange "Trickle charge" light.
Supply voltage: 100/120/230 V AC, 60 Hz
Classification: Class II, per IEC 601-1

9. TROUBLE-SHOOTING LIST

If the steps listed below in the trouble-shooting guide fail to correct the problem, please contact an authorized service representative for assistance.

PROBLEM

STEPS TO CORRECT

Audio

Voice prompts are too quiet or too loud. Re-adjust voice volume using the Setup functions.

Battery

Battery does not easily slide into the device. Verify beveled side of battery is down and contacts are towards opening. Press and hold eject button until battery is inserted about halfway in.

Battery does not eject from the device. Press battery in slightly then retry eject button.

"BATTERY LOW" message displayed. Replace battery with a fully charged battery.

Battery fails the battery capacity test. Review battery charging and maintenance sections. Check battery charger for proper operation. Verify battery expiration date has not elapsed. Charge battery for 16 hours and test capacity of battery. Verify batteries are being charged at least 16 hours between uses.

"REPLACE BATTERY" message. Replace battery with a fully charged battery.

Battery Charger

Fast Charge LED doesn't turn OFF after 8 hours. Remove battery and check that the Fast Charge LED turns OFF.

Allow 16 hours to recharge a fully discharged battery, then recheck the Fast Charge LED. Try charging a known good battery.

Power LED not on. Check if power cord is plugged in. Check if voltage is present at the wall socket.

Trickle and Fast LEDs OFF with battery installed. Remove and re-install battery. Check for dirty battery contacts. Try charging a known good battery.

Trickle Charge LED not on within 8 hours. Check charger connection to device, verify Power LED is lit. Remove and re-install battery. Check for dirty battery contacts. Allow 16 hours to charge a fully discharged battery, then recheck the LED. Try charging a known good battery.

MCM

Check Module MCM not operating. The Heartstart 911 does not recognize the Check Module MCM. No data will be stored in this MCM.

Standard Module (HS - 2000) MCM not operating. The Heartstart 911 does not recognize the Standard Module MCM. No data will be stored in this MCM.

Manual (Paramedic) MCM Plus not operating. The Heartstart 911 does not recognize the Manual (Paramedic) MCM Plus. Data can be stored in this MCM.

"MCM BATT. LOW" warning. Replace the MCM with another module, at the next opportunity, then download the internal MCM (if less than 24 hours). This MCM should be serviced and its battery replaced.

Medical Control report contains square wave ECG segment. This is required to obtain a shock summary report and does not represent patient ECG data.

Top of Medical Control report shows device as Heartstart 3000. This is normal for the standard reporting devices. The Event Log report will show "HS-911" as the device.

Medical Control report not printing. Try printing from another reporting device, if available. Check device's MCM connector for bent pins. If MCM battery low warning given, return the MCM for Service.

Operation

| | |
|---|--|
| Energy sequence or device operation incorrect. | Verify device is configured correctly, in the Setup function. |
| Charging taking longer than 20 seconds. | Turn device OFF then back ON and retry. |
| "CHECK ELECTRODES" message. | Verify electrodes are attached to patient. Verify patient cable is securely connected to electrodes and device. Verify electrodes are firmly adhered; apply even hand pressure to electrode, if needed. If electrodes are expired, dried out, or otherwise defective, remove and apply a new set to the patient. Cables may be tested using the Automatic Self Test. |
| Clock or date is incorrect. | Update time or date using Setup functions. Check for CLOCK warnings. |
| Continuous beep is heard. | Check for "MANDATORY" messages. Turn device OFF and ON, and retry. |
| Buttons do not operate. | Run the Heartstart 911 Setup function to test for proper button operation. |
| Device automatically turns ON and starts to charge. | This is normal operation if the Automatic Self Test function is enabled and scheduled. The Auto Self Test can be disabled, using the Setup functions, if desired. |
| Device disrupts operation of other equipment. | Remove all non-essential equipment from the patient when the Heartstart 911 is being used. Reposition the patient cables and/or change equipment orientations. Increase the distance from the Heartstart 911 to the equipment being affected. |
| Device fails to turn OFF. | Eject battery to turn the device OFF. Re-insert battery and turn device ON. |
| Device fails to turn ON. | Keep ON button pressed down until a beep is heard. Verify battery is installed and fully inserted. Replace battery with a fully charged battery. |
| Device turns OFF during use. | The device turns itself OFF automatically if the electrodes are not attached or the "ATTACH ELECTRODES" message remains on for more than 2 minutes. Replace battery with a fully charged battery. Check for "MANDATORY" messages. |
| Display backlight is not on. | Check if the display works in low light conditions. |
| Warning messages are flashing ON and OFF. | Review the 'Device Warnings During Operation' section of this manual. This flashing is normal for the battery status messages, warnings, the battery symbol, and the wrench shaped warning symbol. |
| Patient Cable will not plug into device. | Verify the patient cable is a Heartstart 911 cable. Heartstart 1000 or 3000 patient cables will not work with a Heartstart 911. |
| "MANDATORY" message displayed. | Note code number of Service Mandatory message. Turn device OFF and ON. Use another device if available. Discontinue use as soon as possible and return the device for service. |
| Service warning displayed. | Note code number of warning. Turn device OFF and ON. Use another device if available. Discontinue use as soon as possible and service device at your earliest convenience. |

10. APPENDIX A HEARTSTART 911 PREPAREDNESS CHECK LIST

Note: This form may be freely copied and used.

Preparedness check list

Date: _____
S/N : _____

Shift: _____

Location: _____
Operator: _____

Directions: Perform the following inspections and tests. Check off each item and note any required corrective actions that were taken.

| | | Check off | Corrective Action or Comment |
|--|--|--------------------------|------------------------------|
| Defibrillator Device | Device and storage pouch are clean. | <input type="checkbox"/> | |
| | No fluids have been spilled on the device. | <input type="checkbox"/> | |
| | No objects stored on top of device. | <input type="checkbox"/> | |
| | Case is not cracked or damaged. | <input type="checkbox"/> | |
| Cables and Connectors | Cable is not cut, abraded or damaged. | <input type="checkbox"/> | |
| | Snap connectors are clean and undamaged. | <input type="checkbox"/> | |
| | Patient cable is securely attached to device. | <input type="checkbox"/> | |
| | Test load snap connectors are clean and undamaged. | <input type="checkbox"/> | |
| Replacement Supplies | Two sets of electrodes, in sealed packages, within expiration date. | <input type="checkbox"/> | |
| | Electrode packages in good condition and stored flat. | <input type="checkbox"/> | |
| | Skin prep supplies available (towel, razor, wipes, etc.) | <input type="checkbox"/> | |
| | *MCM Plus, cleared before use, in accessory slot. | <input type="checkbox"/> | |
| Batteries | Fully charged battery in device, within replacement date. | <input type="checkbox"/> | |
| | Fully charged spare battery, within replacement date. | <input type="checkbox"/> | |
| | If fully charged battery is on charge, the "TRICKLE" light should be on. | <input type="checkbox"/> | |
| Functional Checkout | *If using auto selftest feature with test load connected to cable: | | |
| | Last daily auto selftest was OK and is displayed. | <input type="checkbox"/> | |
| | *MCM Plus report indicates daily auto selftests were OK. | <input type="checkbox"/> | |
| | If not using auto test feature: | | |
| | Connect cable to test load then power ON device in setup mode. | <input type="checkbox"/> | |
| | Activate the auto selftest and verify that all tests are OK. | <input type="checkbox"/> | |
| | Power OFF device., remove test load and restore cable. | <input type="checkbox"/> | |
| *MCM Plus report indicates auto selftests were OK. | <input type="checkbox"/> | | |
| Verify proper display operation during tests. | <input type="checkbox"/> | | |
| Standby Recharge | Verify device is turned OFF and connected to battery charger. | <input type="checkbox"/> | |
| | Verify battery charger's power light is on. | <input type="checkbox"/> | |

Major problem(s) identified, device taken out of service.
Device needs to be serviced.

* Denotes optional accessories

11. APPENDIX B HEARTSTART 911 PERIODIC CHECK LIST

Note: This form may be freely copied and used.

Periodic check list

Date: _____
S/N : _____

Shift: _____

Location: _____
Operator: _____

Directions: Perform the following inspections and tests. Check off each item and note any required corrective actions that were taken.

| | | | |
|----------------------------|--|--|--|
| Defibrillator Operation | Connect cables to Heartstart Tester (P/N 903800). Power ON device and Tester. Verify device's self test at power ON is OK, no errors reported. Verify proper operation of the device: Shock delivered for V. F. and V.T. fast rhythms. No shock delivered for Sinus, V.T. slow or asystole rhythms. Power OFF device and Tester. *MCM Plus report indicates proper test sequence. | <input type="checkbox"/> <input type="checkbox"/> <input type="checkbox"/> <input type="checkbox"/> <input type="checkbox"/> <input type="checkbox"/> <input type="checkbox"/> | |
| Battery Maintenance | Verify for battery currently in service: Battery in device has been tested for capacity in last 6 months. Spare battery has been tested for capacity in last 6 months Battery in device recommended replacement date has not elapsed. Spare battery recommended replacement date has not elapsed. | <input type="checkbox"/> <input type="checkbox"/> <input type="checkbox"/> <input type="checkbox"/> | |

Major problem(s) identified, device taken out of service.
Device needs to be serviced.

* Denotes optional accessories

USA and Latin America

LAERDAL MEDICAL CORPORATION
167 Myers Corners Road, P.O. Box 1840
Wappingers Falls, New York 12590-8840
Telephone (800) 431-1055, (914) 297-7770
Telefax (800) 227-1143, (914) 297-1137

Canada

LAERDAL MEDICAL CANADA LTD.
70 Ironside Cres., Unit #2
Scarborough, Ontario M1X 1G4
Tel. 1-800-265-9987, (416) 298-9600
Fax (416) 298-8016

United Kingdom

LAERDAL MEDICAL LTD.
Laerdal House, Goodmead Road, Orpington,
Kent BR6 0HX
Tel. 01689 876634, Fax 01689 873800

Germany

LAERDAL
D-81249 München, Am Loferfeld 56
Telefon: 089 / 864 20 00
Telefax: 089 / 864 34 84

France

LAERDAL MEDICAL FRANCE S.A.
Evolvic 5 - 1 rue des Vergers - 69760 Limonest
Tél. (04) 72 52 02 52, Fax (04) 78 35 38 45

Italy

LAERDAL ITALIA S.R.L.
Via dei Lapidari, 13
40129 Bologna
Tel. 051-320087, Fax 051-320137

Spain

LAERDAL ESPAÑA, S.L.
Manuel Tovar 19
28034 Madrid
Tel. 34-1-7291110, Fax 34-1-7291125

Benelux

LAERDAL BENELUX N.V.
Business Park Luchthavenlaan,
Jan Olieslagerslaan 33, B-1800 Vilvoorde
Tel. 32-2-253 36 96, Fax 32-2-253 36 90

Australia

LAERDAL Pty. Ltd. (ACN 003 817 490)
23 Edward Street, Huntingdale, Victoria 3166
Tel. (03) 61 3 9569 4055, Toll free 1800 331 565
Fax (03) 61 3 9569 4028, Toll free 1800 635 835

Far East

LAERDAL Far East Rep. Office,
7A Dalhousie Lane, Singapore 209676
Tel. 292 2880, Fax 292 3212

Sweden

LAERDAL MEDICAL AB
Box 2064, 132 02 Saltsjö-Boo
Tel. 08-7150300, Fax 08-7471648

Finland

LAERDAL OY
Vattuniemenranta 2, 00210 HELSINKI
Puhelin 09 - 692 77 22, Tilaukset 09 - 692 76 22,
Telekopio 09 - 692 77 99

Denmark

LAERDAL DANMARK A/S
Frederikssundsvej 274, DK-2700 Brønshøj
Tel. 38-607744, Fax 38-607732

Norway

LAERDAL
P.O. Box 377, N-4001 Stavanger
Tel. 51 51 17 00, Fax 51 52 35 57



Laerdal
helping save lives